

StowAway²

Cargo Carriers

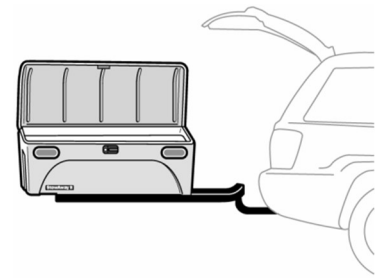
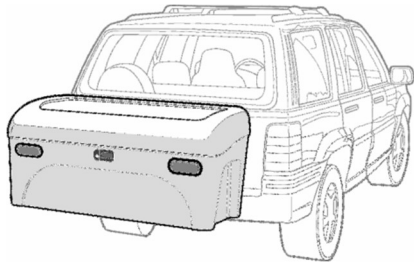

Assembly Instructions

For StowAway SwingAway Models
022.3, 022.3LT and 024.3 Max
(Rev. 0824)

Thank you for purchasing a StowAway Carrier. Please review the following instructions and safety guidelines carefully before assembling the StowAway Carrier. Assembly and installation of the StowAway is best done by two people given the size and weight of the StowAway components. Assembly and installation of the carrier are solely the end user's responsibility. Assembly videos are available at our **video library** <https://www.stowaway2.com/video-library>

StowAway Warnings and Guidelines

- **EXHAUST WARNING** – Hot exhaust directed at or below the StowAway box could melt or damage the box and its contents. For vehicles with straight back exhaust it is recommended that the exhaust be diverted with an exhaust pipe tip or deflected from the box with a StowAway or comparable exhaust shield(s). StowAway exhaust shields can be purchased separately for both the driver and passenger sides of the vehicle. Exhaust shields are not necessary on vehicles with tail pipes that direct the exhaust down or to the side.
- The StowAway Carrier is not intended for moderate or heavy off-road use, or for use on rough or washboard roads. When using the carrier on dirt or gravel roads, be sure to travel at appropriate speeds to minimize impacts and jarring movements, and to prevent overstressing the box & frame. Note that use on rough or washboard roads may lead to damage to the carrier or vehicle for which Pacific Recreational Products is not liable.
- StowAway models designed for a 2" hitch receiver should be used with a Class III or IV 2" receiver hitch. StowAway models designed for a 1.25" hitch receiver should be used with a Class II, 1.25" hitch receiver. We do not recommend the use of a 1.25" to 2" hitch converter with the StowAway carrier under any conditions. A seven inch hitch extender can be used with Class III or IV hitches rated for more than 500 pounds tongue weight. Under no circumstances should the hitch tongue weight, vehicle tongue weight, or the vehicle gross vehicle weight be exceeded.
- Before driving, be sure that all knobs, bolts, screws, and locks are firmly attached, tightened and locked, and that the SwingAway frame is latched and both safeties are engaged. Knobs, bolts, screws, locks, the box, and the frame must be regularly inspected for signs of wear, corrosion, fatigue, or other damage. Discontinue use if signs of wear, corrosion, fatigue, or other damage are found.
- When traveling with the StowAway Carrier, obey posted speed limits and traffic cautions. Adapt your speed to the condition of the road, the load being carried, and the overall vehicle length with the carrier installed.
- For optimal load balance, the StowAway should be loaded with light, bulky items rather than dense heavy items. Never exceed the capacity of your carrier. Use caution when swinging the carrier away from the vehicle and do not step on the frame when in the open position.
- Do not use the StowAway to transport people, animals or flammables. Do not transport items on the lid of the carrier, or use the lid as a work area, unless the unit is equipped with the StowAway lid rack. If your StowAway is equipped with the lid rack, do not load the rack with more than 15 pounds or damage to the carrier may result.
- **Always keep the carrier's lid latched and locked when not accessing the box to maintain alignment of the lid teeth.** Do not allow people to climb on, get into, or sit on the StowAway at any time.
- Rinse and lightly oil the StowAway frame and hardware after traveling on salted roads or using the StowAway in a salt air environment. Coating the inside and outside of the frame with a rust preventive product is advised in the case of regular exposure to salt or salt air.



StowAway²

Cargo Carriers

Assembling the StowAway Carrier

Open all cartons and packaging to remove parts for assembly.
Save all packaging until the unit is fully assembled and functional.

Box

1. StowAway Lid (Standard or Max)
2. StowAway Base (Standard or Max)

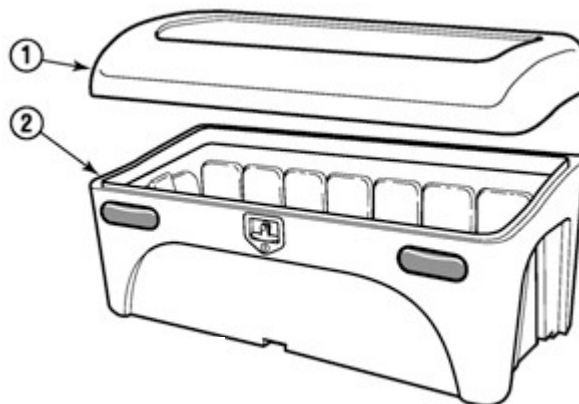

SwingAway Frame

3. Swing Arm
4. Bent Hitch bar

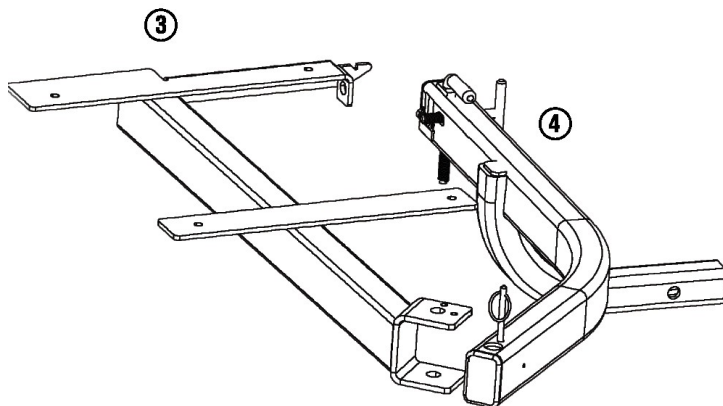

Hardware Kit

5. 1 - Drain Plug
6. 3 - Hinge Pins (pre-installed if box is assembled)
7. 4 - 3/8" Bolts
8. 4 - Metal and 4 Rubber Oblong Washers for Mounting Box
9. 4 - 7/8"* Flat Washers for Mounting Box
10. 4 - Nylok Lock Nuts
11. 1 - 3/4" Pivot Bolt
12. 4 - 1.5"* Flat Washers for Pivot Bolt
13. 1 - 3/4" Nylok Lock Nut for Pivot Bolt
14. 3 - Releasable Cable Ties
15. 1 - Hitch Pin (or Hitch Lock)
16. 1 - Hitch Tightener
17. 1 - Lid Stay (Standard Box ONLY)

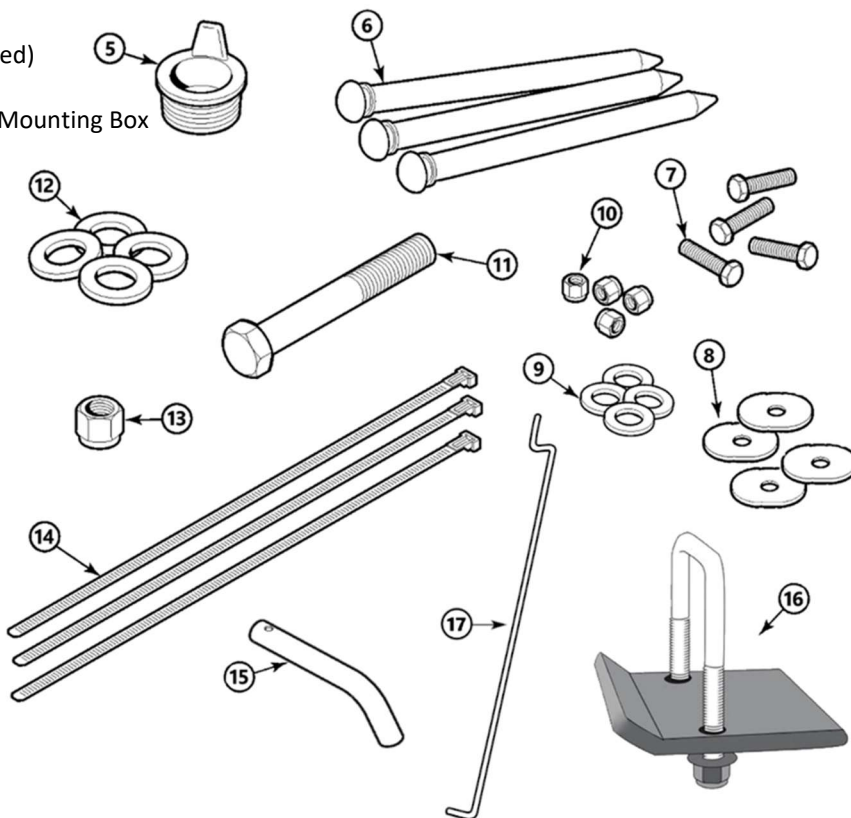

Note: The keys and instructions bag will be hanging on the right latch rod in the box. This is located directly behind the latch handle of the locking latch.

Tools Required for Assembly

Two large adjustable end wrenches or socket wrenches with 9/16" and 1 1/8" sockets. A flat head screwdriver.

*Indicates outside diameter measurement

StowAway²

Cargo Carriers

1. Assembling the Frame

- Slide the bent hitch bar into your vehicle's trailer hitch until the hitch pin holes are aligned (Fig 1). Locate the Hitch Pin or Hitch Lock from the hardware kit and insert the pin into the hitch. The hitch tightener need not be installed at this time unless you plan to use the StowAway immediately.
- Fit the swing arm yoke over the point of rotation on the hitch bar (Fig 2). Position two pivot bolt washers (Fig 3), one on top of the yoke and one between the yoke and bar, then insert the pivot bolt through the yoke and the hitch bar. Insert the third washer between the yoke and bar (grease washer and tap into place if it is tight) before pushing the pivot bolt through the bottom of the yoke. Add the fourth washer to the end of the pivot bolt after the bolt is all the way through and hand tighten the nylok lock nut onto the pivot bolt until you feel resistance. With two large wrenches use firm pressure to tighten the nylok all the way to the bottom of the yoke. Note, tightening the nylok will require firm pressure.
- Test the frame to ensure that the Swing Arm swings freely.
- Close the swing arm to engage the frame (plunger pin) latch. Press down on the swing arm firmly if you experience any interference as you attempt to close the frame. Interference is common prior to the box being installed and loaded. For questions, watch the assembly video on our website.

Fig 1

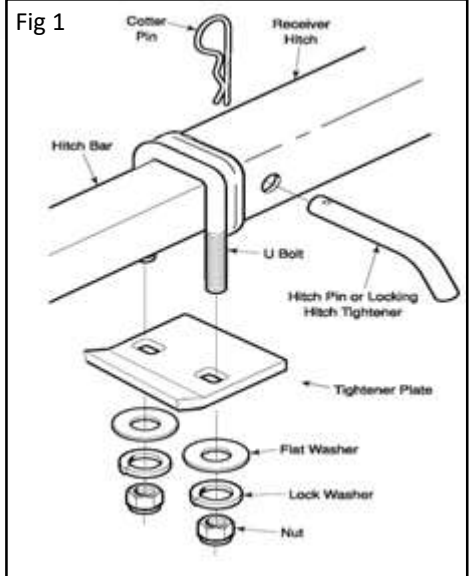

Fig 2

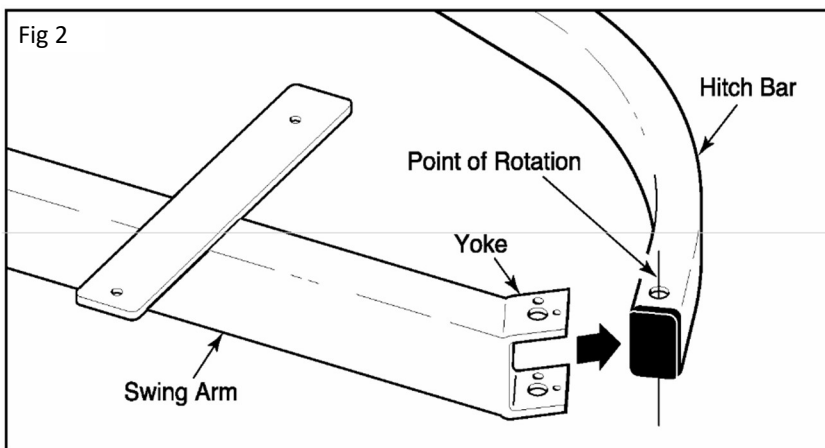
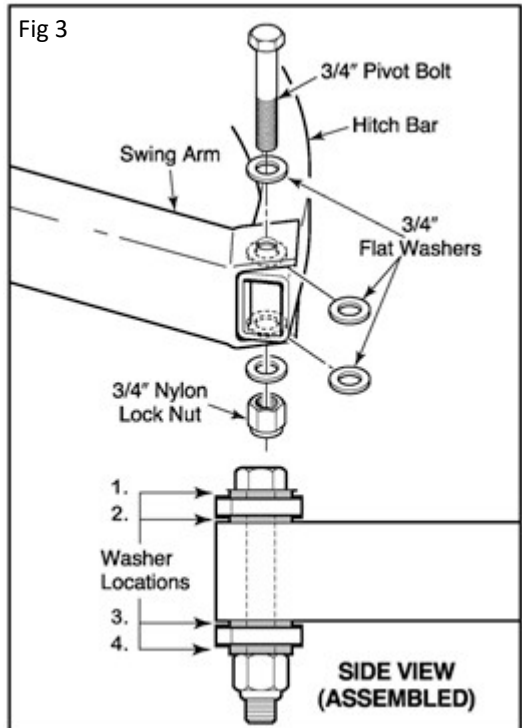

Fig 3



2. Attach Box to Frame

- Be sure that the swing arm is closed and latched.
- **Note: If you ordered the exhaust shield(s) you will want to install these now before mounting the box to the frame. See the exhaust shield installation instructions.**
- Position the box on the frame so that the box latch faces rearward and the mounting holes are aligned. Place a rubber oblong washer over each mounting hole, followed by a metal oblong washer. Insert a bolt through each hole and the frame (Fig 4). Slide a flat washer and locknut onto each bolt and tighten, repeating for each bolt. **Note, if you ordered the wheel kit you will install the wheels instead of the locknuts to the two rear bolts. (See Wheel Kit instructions).**

Fig 4

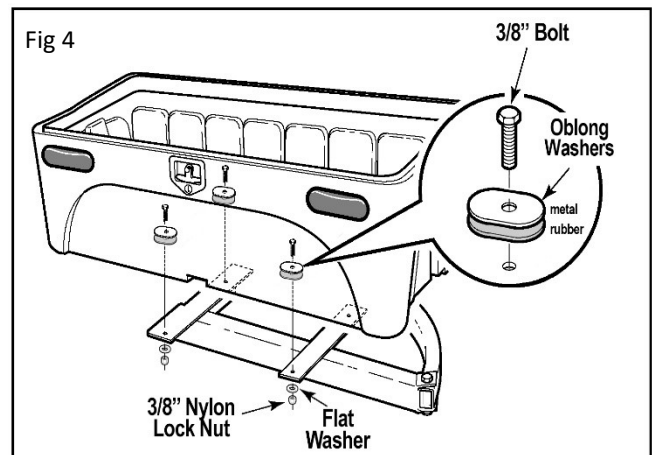

StowAway2

Cargo Carriers

3. Attach Lid to the Base of the Box

- (Ignore this section if your box is pre-assembled). Locate the nylon hinge pins.
- Position the lid on the base of the box with the lid in the open position. Align hinge pin holes in the lid and the base.
- Reach under the inner lip at the back of the box and push the left hinge pin into position (Fig 5). The pin should be pushed all the way to the hinge pin collar, but no further. Repeat this process with the right hinge pin, followed by the center pin. It will be necessary to reach under the wire harness when installing the right hinge pin. A small hammer can be used to tap the pins into place if necessary.
- Locate and remove the keys from the right latch rod.
- Close the lid, press down firmly on the lid with one hand and turn the latch with the other hand. The latch rods will slide into the lid teeth bushings and engage. If your latch rods do not engage it is likely that the lid teeth have moved slightly during shipping (temperature fluctuations can cause this). To realign the lid teeth, face the StowAway from the front (latch side) of the box, grab and pull each of the lid teeth toward yourself with about 10 to 15 pounds of pressure. Hold this position for roughly 30 seconds and try again to latch the box. If the latch rods still do not engage, repeat this process once again. Refer to the StowAway2.com video library for a video "Latching the StowAway Cargo Carrier" for further help. Always store the StowAway with the box latched to maintain alignment of the lid teeth.
- The Max box is designed with a notch to hold the lid open at 90 degrees. It is normal to feel resistance as the lid approaches 90 degrees when opening.

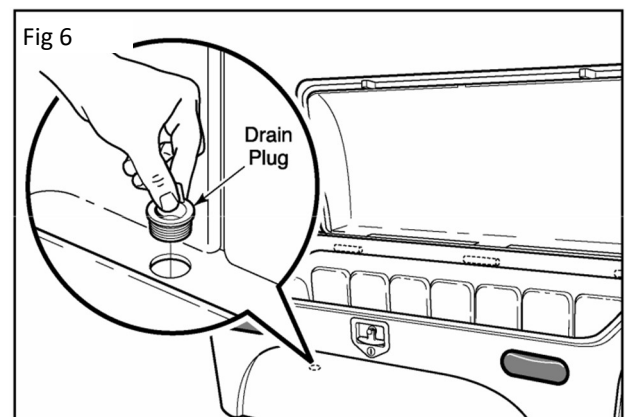
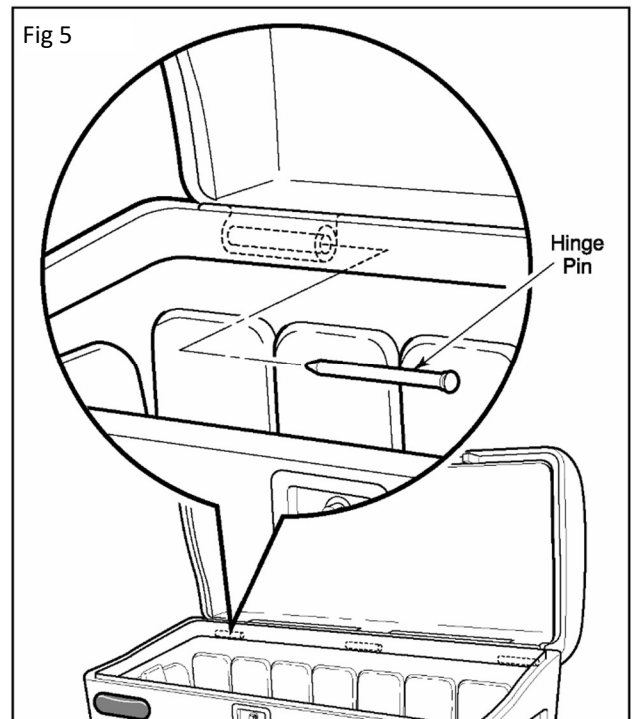

4. Final Assembly

- Note that the cargo box and swingaway frame are assembled and tested to ensure that the frame closes and latches properly. It may be necessary to push down slightly on the empty carrier to ensure proper latching. To release the frame, pull up on the plunger pin handle (Next Page, Fig. 8).
- Push the drain plug into the drain hole at the bottom of the cargo box (Fig 6).
- Pull the wire harness through the back of the box. Secure the harness to the hitch bar with the releasable cable ties (Fig 7), making sure the harness has enough slack for the closed or open positions, but is not pinched when the box is swung closed. Do not allow the harness to rest in front of the exhaust pipe.
- Plug the StowAway wire harness into your vehicle's wire harness plug located on the driver's side of the hitch receiver. You may need an electrical adapter if your vehicle plug is not compatible with a four flat connector. Electrical adapters are available on StowAway2.com or through automotive or hitch stores.
- Check all lights to ensure that they are working properly.

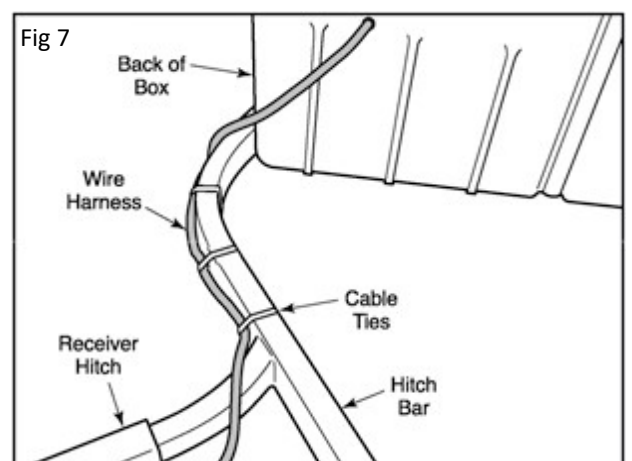

StowAway2

Cargo Carriers

Using the StowAway Carrier

- For optimal weight distribution, it is best to load the StowAway Carrier with your light and bulky items, saving dense and heavy items for the vehicle. Pack your gear with the weight distributed evenly across the bottom of the box to prevent any box distortion.
- Do not pack items too closely to the StowAway latch or taillights to avoid latch or taillight interference.
- The StowAway cargo box is designed to prevent water from penetrating the interior of the box. The standard box uses a gasket for this purpose while the Max box uses a water channel and weep holes to channel water to the outside. Be sure to keep the weep holes clear of debris to ensure water drains to the outside. While these water prevention systems work effectively under common conditions, water or dust may penetrate the box in more severe and humid conditions so please pack your items accordingly.
- Packing wet items into the box and some humid conditions can create condensation in the box and cause all items to get wet. Be sure to drain and dry your items and the box interior to prevent condensation.
- A hitch lock will secure the StowAway Carrier to your hitch. Hitch locks are available through StowAway2.com or through automotive or rack stores.
- The StowAway SwingAway models come with a lit license plate bracket for mounting your rear license plate bracket on the carrier. Moving your license plate to the StowAway may not be necessary if your plate is clearly visible with the StowAway installed.
- The SwingAway frame is equipped with a latch, a primary and a secondary safety. To close the frame, swing it closed until the latch engages. Tighten the primary T-Bolt safety fully until the T-Bolt washer is flush to the frame. Be sure that the threads are properly aligned when tightening the bolt. Drop the secondary safety into place at the pivot point.
- To open the frame remove both safeties and pull up on the orange plunger pin.
- The SwingAway frame may be locked at 90 degrees from the vehicle by inserting the safety pin into the hole at the pivot point. Care should be taken when swinging the cargo box out near traffic or on an incline. The cargo box should be loaded with the frame in the closed position if possible.
- Lid Stay – Each Standard box comes with a lid stay to help keep the lid in the open position. The box and lid are pre-drilled for the lid-stay on the left hand side. NOTE: The Max carrier has a self-supporting lid so does not include a lid stay.
- While the StowAway is equipped with a locking latch and rods a determined thief may access the box's contents by compromising these components. Care should be taken when storing and transporting valuables in the StowAway.
- The lights are designed to provide taillight, brake light, and turn signal functionality. Each light is tested for full functionality at the factory before shipping. If the lights do not appear to be functioning properly, please try the following steps:
 - Test the unit on another vehicle. Improper or oxidized vehicle wiring can be the source of carrier lighting problems.
 - Spray WD40 into or onto the vehicle wiring plug and the StowAway four pin connector. Corrosion on these connectors is a common source of lighting problems. Check this connection and the plugs at each taillight to ensure that each is tight.
 - Consult your vehicle owner's manual to ensure that the terminals on the vehicle plug match the functions of those on the StowAway2 (Fig 3).

Fig 8

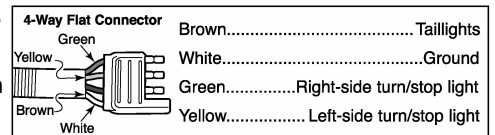
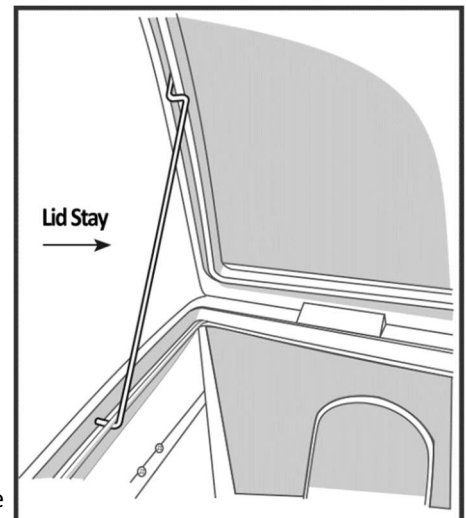
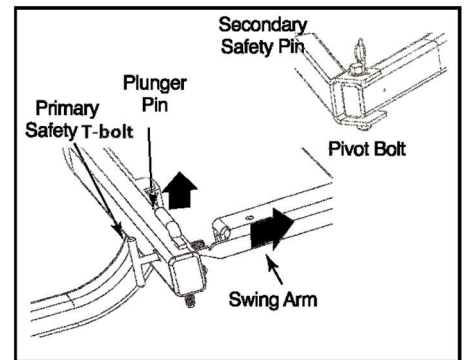
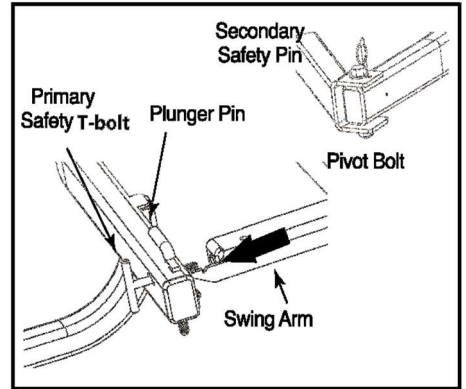

Fig 3

CALL US FIRST!

For help with assembly or missing / damaged parts, call us at

1-800-943-5377

Our staff will be happy to help you!

StowAway²

Cargo Carriers

Caring for your StowAway Carrier

1. The StowAway is equipped with a drain plug for ease of cleaning. The exterior surface of the cargo box may get dull or dirty and can be washed with dish soap and water and a wash mitt to get into the texture. **Trim Shine** Plastic Protectant can be used to restore the luster to the **black** StowAway box, and is generally available through auto parts or accessories stores or online.
2. The StowAway frame should be washed, rinsed and dried after each use to remove road grit or salt from the frame. Any sign of rust should be sprayed with rust remover/preventative at once. Moving frame components, e.g. the pivot bolt, plunger pins and safeties, should be kept lubricated. Road salt will cause the frame to rust and deteriorate quickly unless the frame is rinsed, dried and lubricated after each use. Rustoleum (black) can be used for paint touch up.

Warranty on the StowAway Cargo Carrier

Pacific Recreational Products, Inc. (PRP) warrants to the original retail purchaser of the StowAway Cargo Carrier that the box, frame, and hardware shall remain free of defects, including materials and workmanship, for a period of ten (10) years from the date of retail purchase. The carrier electrical system and any purchased accessories are warranted to remain free of defects in materials and workmanship for a period of one (1) year from the date of retail purchase.

Should the purchaser discover a defect and notify PRP during this 10-year warranty period, PRP will, at its sole discretion, either (A) repair or replace the unit at no additional charge, or (B) refund all or part of the customer's original purchase price.

This 10-year limited warranty does not cover normal wear & tear, damage caused by exhaust gases, rust, or corrosion, or damage caused by collision, disaster, abuse, modification, misuse, or use on unpaved surfaces. Misuse includes, but is not limited to, overloading the carrier, improper installation, or use with any hitch receiver of an incorrect size or style.

Limited warranty service may be obtained by first calling or writing to PRP and describing the problem or perceived defect. PRP may request documentation in order to fully understand the nature of the problem or defect. If a defect or problem is confirmed, PRP will, at its sole discretion, replace, repair, or authorize the return of the product in the original shipping container or its equivalent. Unless otherwise authorized, return transportation charges must be prepaid by the purchaser.

All expressed and implied warranties for this product, including the warranties of merchantability and fitness for a particular purpose, are limited in duration to a period of ten (10) years from the date of purchase. No warranties, whether expressed or implied, will apply after this period.

If this product is defective, your sole remedy shall be repair, replacement, or refund as provided above. In no event will PRP or any of its officers, employees, or agents be liable to you for any damages. This includes incidental or consequential damages arising out of the use of or inability to use the cargo carrier, even if PRP has been advised of the possibility of such damages, or for any claim by another party.

To initiate a warranty claim, please fill out the Return Request Form on our Returns & Exchanges page. Consult our website StowAway2.com for assembly videos and other product information.

Pacific Recreational Products, Inc.
7291 SW Tech Center Drive • Tigard, OR 97223
Ph.: 800.943.5377 • Fax: 503.968.1433
www.StowAway2.com
E-mail: customerservice@StowAway2.com
Thank you for purchasing a StowAway2 Cargo Carrier!

